

STELLAR BLAST 450 M4 1,1kW (509123050)

GENERAL DATA



UP-BLAST TRANSMISSION VERTICAL DISCHARGE ROOF FAN MADE OF ALUMINUM

CONSTRUCTIVE FEATURES

- Up-Blast exhaust fan made entirely of aluminum that guarantees excellent corrosion resistance and minimum weight.
- Oversized Belt & Pulley Transmission (150% of the installed power). Oil and Static resistant belts.
- Bearings 100% factory tested and designed specifically for air movement applications with an L10 rating of 50,000 hours.
- Anti-vibration blocks reduce motion and noise transfer between transmission system and fan housing.
- High-performance aluminum built backward inclined impeller with self-cleaning system to minimize noise and vibrations.
- Q6.3 grade, statically and dynamically balanced fan for long life and quiet operation.
- Specially designed housing for rain protection. Protective grille to prevent entry of objects.
- Drain tube for easy removal of fluids (water and grease).
- Coated motor cable to prevent overheating and ensure long motor life.
- Standardized squirrel cage asynchronous motor with IP-54 protection and class F insulation. Standard voltages 230V 50Hz single-phase and three-phase motors.
- Inox bucket for grease collection, FAT TRAP, available for installation after the drain pipe (as accessori)

APPLICATIONS

Designed for deck or roof mounting, vertical discharge, indicated for:

- Professional kitchens.
- Smoke extraction.
- Cinemas.
- Air renewal in all types of buildings and industries.
- Maximum continuous working temperature: 150°C(fluid).
- Maximum ambient temperature: 50°C.

PERFORMANCE CURVE

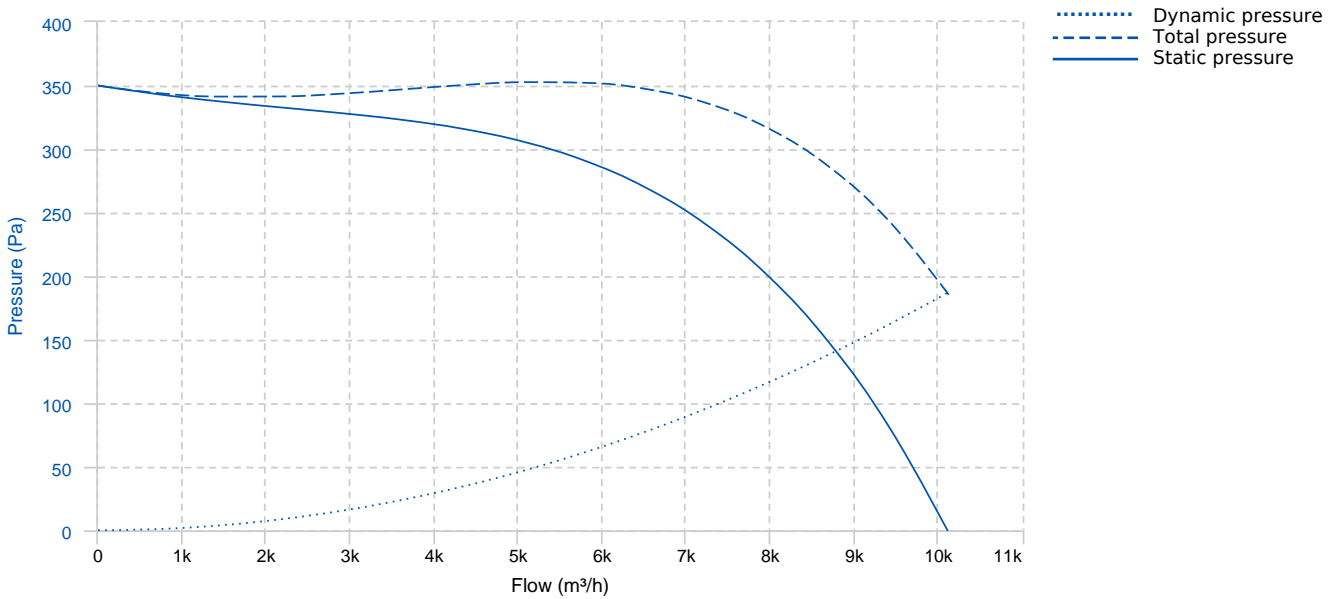

TECHNICAL DATA

Fan							
RPM	1460	Approx. weight	72 kg	Max. Flow	10150 m³/h		
Motor							
Power	1,1 kW	RPM	1460rpm	Capacitor	35mF	I max. (230V)	6,2 A
Size	90S	Approx. weight	14 kg	Efficiency (%)	64 %	FP	0,96

DIMENSIONS

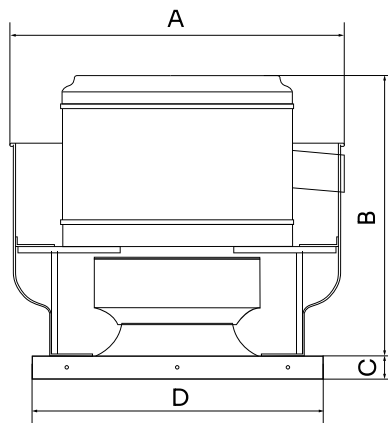

Dimensions (mm)							
A	925	B	718	C	50.8	D	712

WIRING DIAGRAM

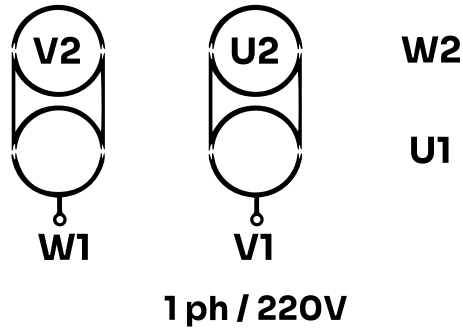

ACCESSORIES



SAFETY SWITCH
INT 25 3P A
REF: INT253PA



STAINLESS STEEL GREASE BOX FOR RESTAURANT EXHAUST FAN FAT TRAP
REF: 509129000

SPARE PARTS

	Code	Model	Qty
1	509123000SP01	MOTOR STELLAR BLAST 450	x1
1	731080701	BELT SPAX 807	x2
1	732111802	PULLEY SPA118-2 (1610)	x1
1	733161024	TAPER 1610D24	x1